

# TAB EXTENDER

Create longer tab length to suit your application!

Increase the distance between your sensor and the Tekscan sensor scanning handle (electronics) with Tekscan's reusable Tab Extender. Sensors can now be used in hard to reach places and in applications that require the sensor scanning handle to be a greater distance from the sensor.

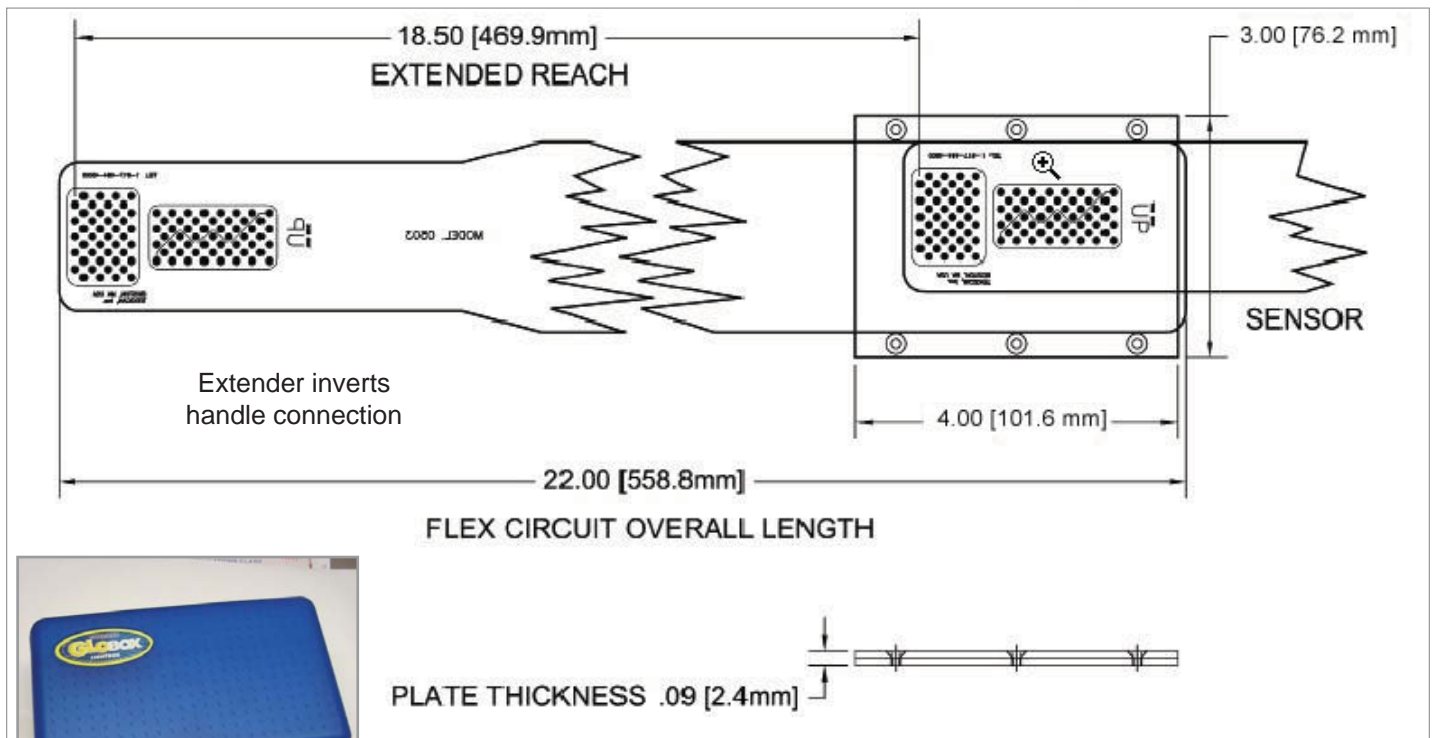

*Lightbox with extender plates and hardware (purchased separately).*

## Applications:

- Pinch/Nip rollers
- Inaccessible locations (pipes)
- Safety considerations (hazardous environments)
- Accessibility (large objects)

## Features:

- Reusable
- Can attach multiple tab extenders to each other for even greater reach

**CALL TODAY FOR A DEMONSTRATION!**

307 West First Street, South Boston, MA 02127-1309 USA  
tel: 617.464.4500/800.248.3669 • fax: 617.464.4266  
e-mail: [marketing@tekscan.com](mailto:marketing@tekscan.com) • website: [www.tekscan.com](http://www.tekscan.com)

